

Electro-Hyd. Circuit - JumboZ-500E

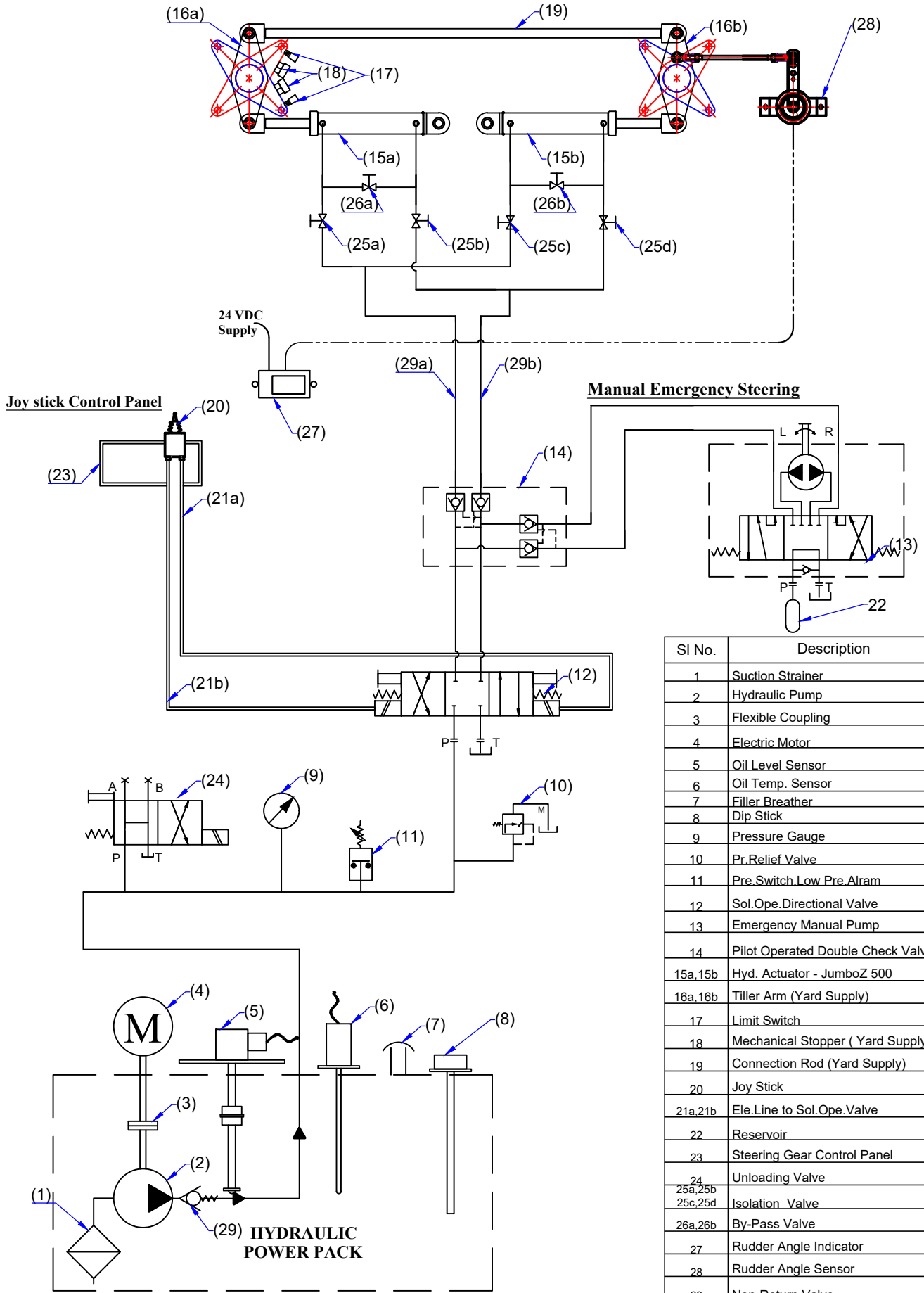

SI No.	Description
1	Suction Strainer
2	Hydraulic Pump
3	Flexible Coupling
4	Electric Motor
5	Oil Level Sensor
6	Oil Temp. Sensor
7	Filler Breather
8	Dip Stick
9	Pressure Gauge
10	Pr.Relief Valve
11	Pre.Switch.Low Pre.Alarm
12	Sol.Ope.Direction Valve
13	Emergency Manual Pump
14	Pilot Operated Double Check Valve
15a,15b	Hyd. Actuator - JumboZ 500
16a,16b	Tiller Arm (Yard Supply)
17	Limit Switch
18	Mechanical Stopper (Yard Supply)
19	Connection Rod (Yard Supply)
20	Joy Stick
21a,21b	Ele.Line to Sol.Ope.Valve
22	Reservoir
23	Steering Gear Control Panel
24	Unloading Valve
25a,25b	Isolation Valve
25c,25d	Isolation Valve
26a,26b	By-Pass Valve
27	Rudder Angle Indicator
28	Rudder Angle Sensor
29	Non-Return Valve



**MAC ♦ N ♦ HOM SYSTEMS
KOCHI - 20**

DESIGNATION	DWG. No.	DATE
Electro-Hydro. Circuit Twin Rudder with Emer.Steering - JumboZ-500E	MHS-1869 (Page 1 of 2)	09.11.2023